



# 1445-1530 MHz Cavity Bandpass Filter

## Part Number: AB1487B933



**ANATECH ELECTRONICS INC**  
RF & Microwave Filters & Products

### Electrical specifications

**Center Frequency:** 1487.5 MHz  
**Passband:** 1445-1530 MHz  
**Insertion loss:** 0.6 dB Max  
**Ripple:** +/- 0.30 dB  
**Return loss:** 20 dB Min  
**Rejection 1:** 80 dBc Min @ 1350-1400 MHz  
**Rejection 2:** 60 dBc Min @ 310-390 MHz  
**Rejection 3:** 40 dBc Min @ 1030-1090 MHz  
**Rejection 4:** 90 dBc Min @ 1575 MHz +/- 10 MHz  
**Rejection 5 :**30 dBc all unspecified bands up to 3 GHz  
**RF power:** 3 Watts

### Mechanical

**Mounting Method:** Threaded Mounting Holes  
**Connector Type:** SMA Female  
**Dimensions:** 6.05" X 6.05" X 1.90" in

### Environmental

**Operating Temperature:** -45 to +85° C  
**Storage Temperature:** -55 to +95° C  
**Shock:** 20 G. 11ms  
**Vibration:** 20 G. 5 to 200 MHz

### Outline Drawing:

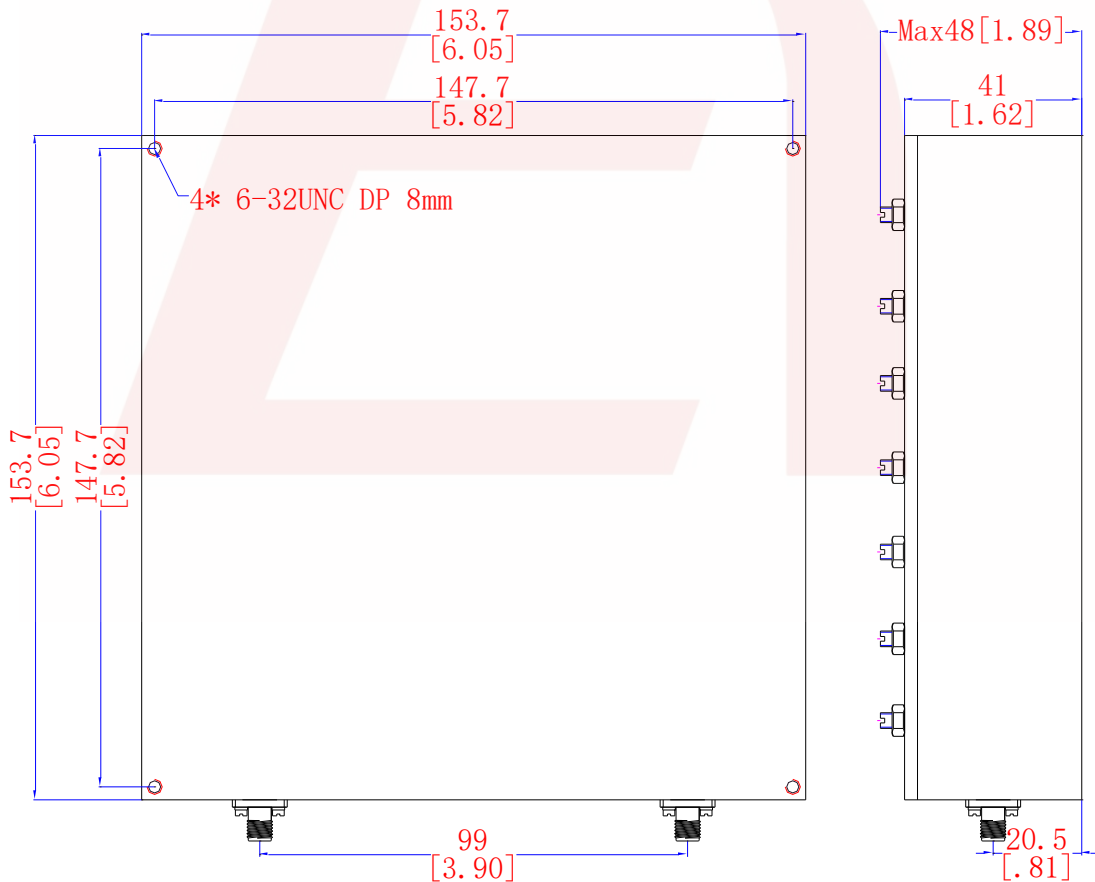

DS07142020 Rev A



# 1445-1530 MHz Cavity Bandpass Filter

## Part Number: AB1487B933

**ANATECH ELECTRONICS INC**  
RF & Microwave Filters & Products



### Response Plot:

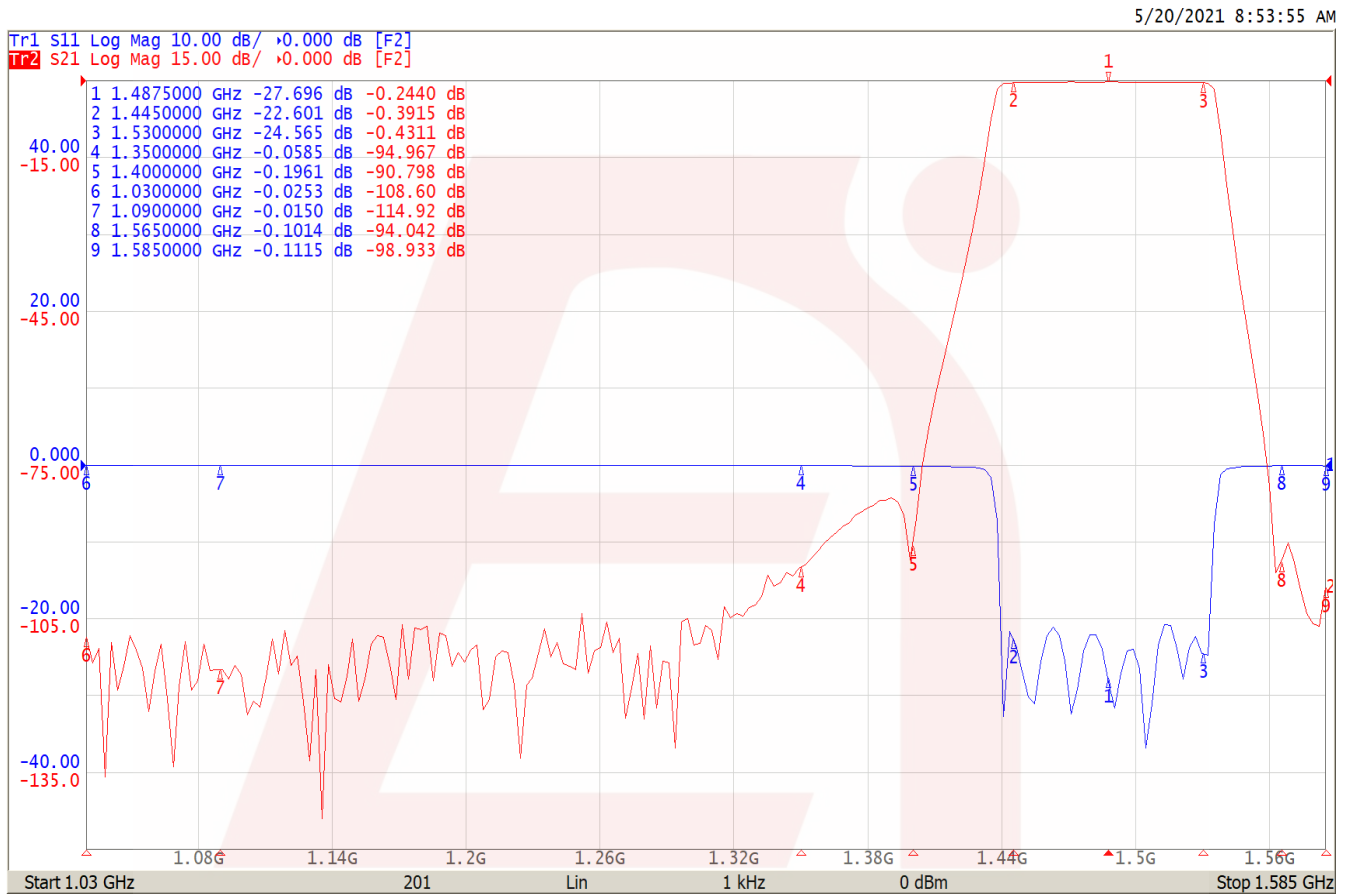

DS07142020 Rev A