



ANATECH ELECTRONICS INC
RF & Microwave Filters & Products

L-Band Communications Cavity Bandpass Filter

Part Number: AB1542B748



Electrical specifications

Center Frequency: 1542 MHz
1.5 dB BW: 20 MHz min
Insertion loss in PB: 2.5 dB max
Return loss: 15 dB min
Rejection: 45 dBc mm @ Fc ± 15 MHz
Impedance: 50 Ohms In/Out
Power Handling: 50 Watts

Mechanical

Mounting Method: Threaded Mounting Holes
Connector Type: SMA Female
Dimensions: 6.46" X 3.31" X 2.25" in

Environmental

Operating Temperature: -45 to +85° C
Storage Temperature: -55 to +95° C
Shock: 20 G. 11ms
Vibration: 20 G. 5 to 200 Hz

Outline Drawing:

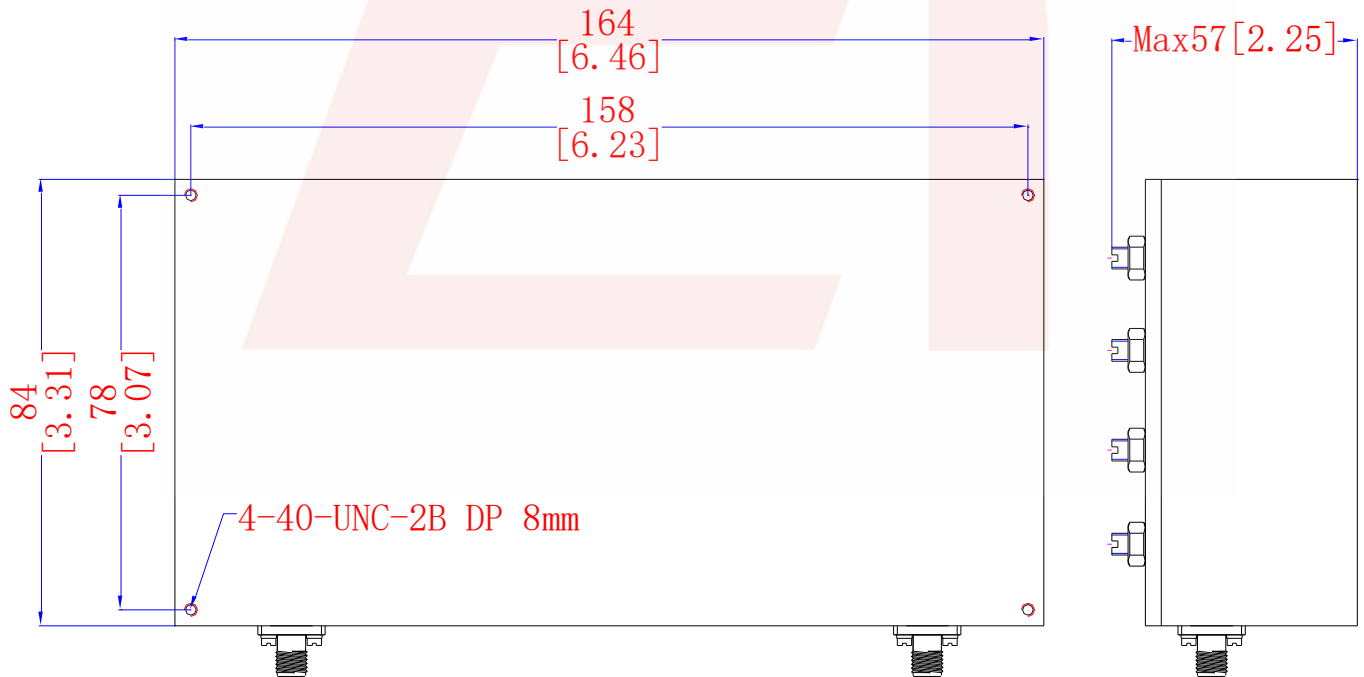

DS-B748-03152018-Rev1



ANATECH ELECTRONICS INC
RF & Microwave Filters & Products

L-Band Communications Cavity Bandpass Filter

Part Number: AB1542B748



Response Plot:

