



ANATECH ELECTRONICS INC
RF & Microwave Filters & Products

1.25 MHz LC Band Pass Filter

Part Number: AE1.25B10710



Electrical Specifications

Center Frequency: 1.25 MHz
Passband bandwidth 1-dB: 67.2 KHz
Passband bandwidth 3-dB: 96 KHz
Passband bandwidth 40-dB: 196 KHz
Passband Insertion Loss: ≤10 dB Max.
Impedance: 50 Ohms In/Out
Power: 0.5 Watts Max.

Mechanical

Mounting Method: Threaded Holes
Connector Type: BNC (F)
Dimensions: 4.0 X 2.0 x 1.0 in

Environmental

Operating Temperature: 15°C to +40°C
Storage Temperature: 5°C to +60°C
Shock: 10 G. 11ms
Vibration: 10 G. 5 to 2000Hz

Outline Drawing:

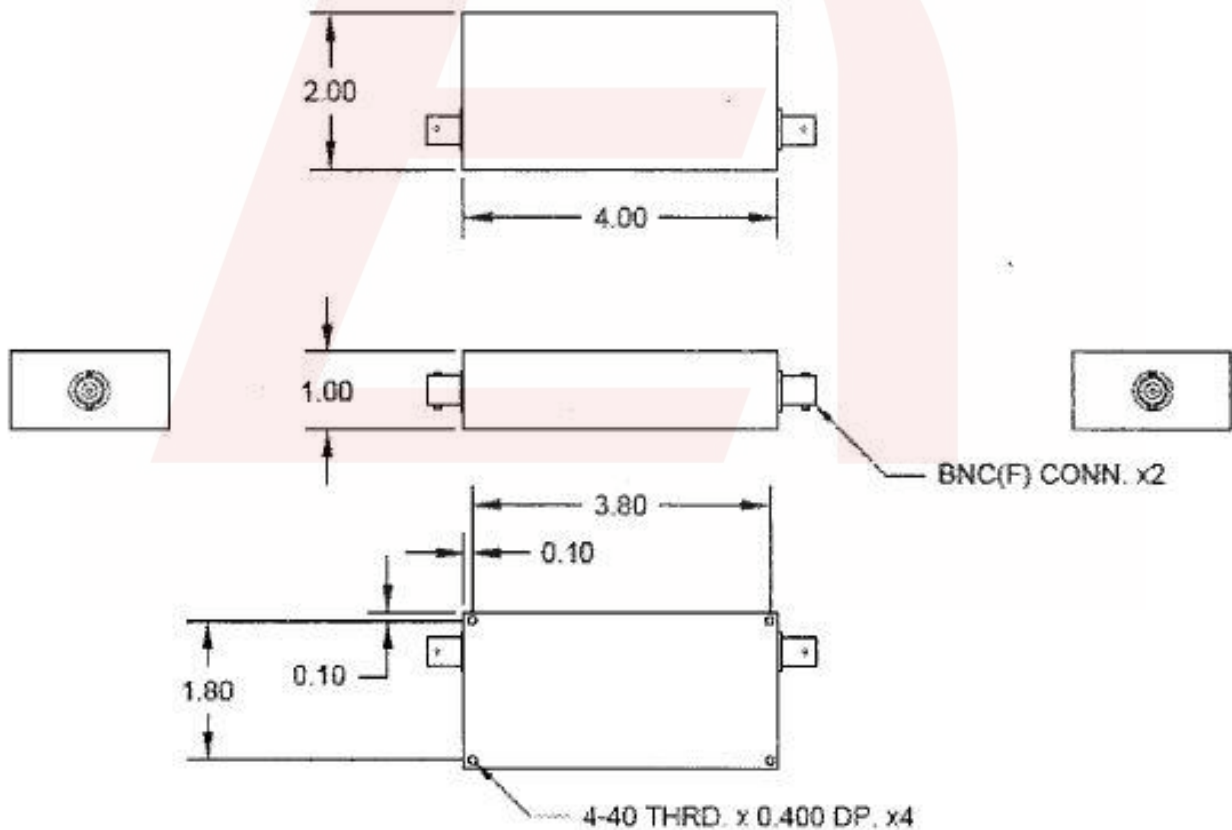



Response Plot:

