



**ANATECH ELECTRONICS INC**  
RF & Microwave Filters & Products

# 1000 MHz LC Lowpass Filter

**Part Number: AE1000LL9339**



## Electrical Specifications

**Cut-Off Frequency:** 1000 MHz  
**Passband:** 500 – 1000 MHz  
**Insertion Loss:** 0.5 dB Max  
**Return Loss:** 10 dB Min  
**Rejection:** 50 dB Min @ 1100 MHz  
                   50 dB Min @ 4000 MHz  
**Impedance:** 50 Ohms In/Out  
**Power Handling:** 200 W

## Mechanical

**Connector Type:** N-Type (F)  
**Dimensions:** 3.50 x 1.65 x 1.16 In.

## Environmental

**Operating Temperature:** -45° C to +85° C  
**Storage Temperature:** -55° C to +95° C  
**Shock:** 10 G.11ms  
**Vibration:** 10 G. 5 to 200Hz

## Outline Drawing:

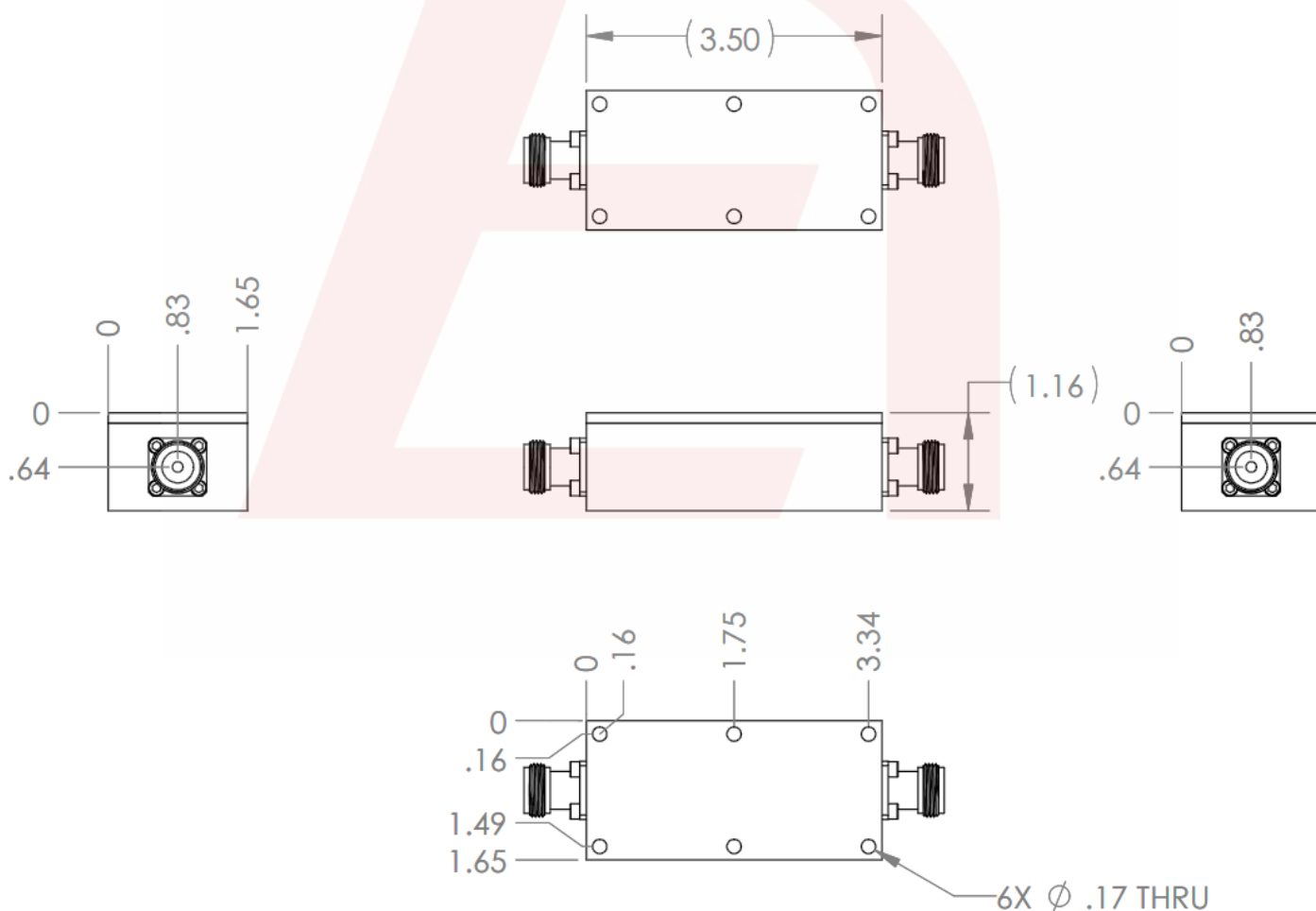

DS-LL9339-05092024-Rev0



### Simulation Plot:

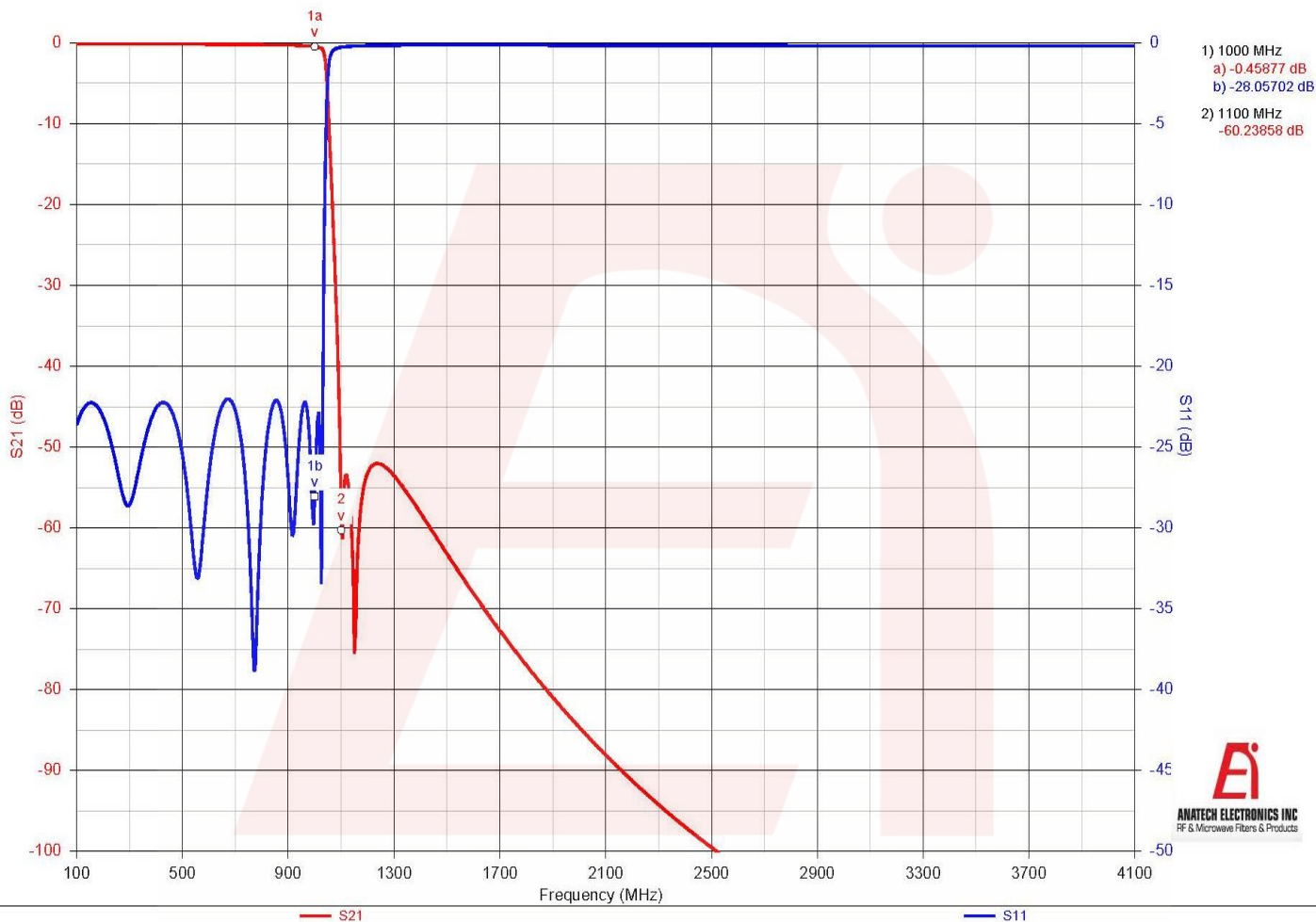

Note: This is a simulation Plot. Actual response plot might differ.