



100-1000 MHz High Pass Filter

Part Number: AE100H9835



Electrical Specifications

Cutoff Frequency (Fc): 100 MHz
Passband: 100-1000 MHz
Passband Insertion Loss : 3.0dB Max.
Passband Return Loss: 14dB Min.
Rejection: 50 dB Min. @ 0-59 MHz
Power Handling: 15 W CW Max

Mechanical

Connector Type: SMA(F) & SMA(M)
Dimensions: 2.5 x 0.75 x 0.5 in

Environmental

Operating Temperature: -25°C to +70°C
Storage Temperature: -60°C to +90°C
Shock: 10 G. 11ms
Vibration: 10 G. 5 to 2000Hz

Outline Drawing:

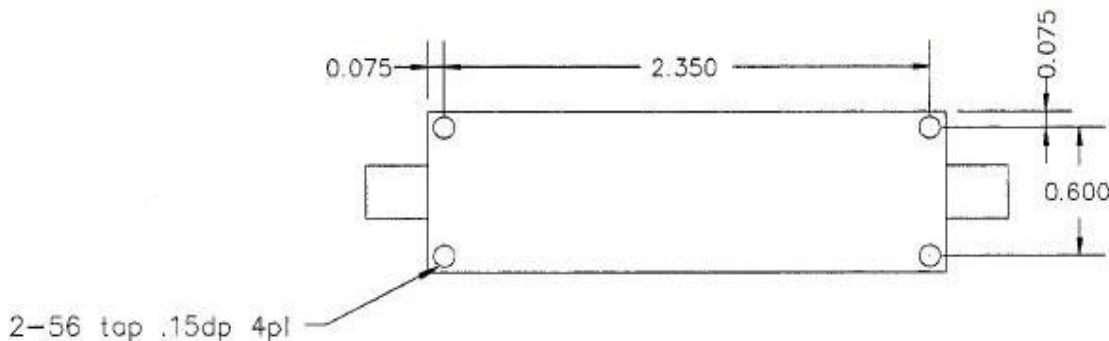
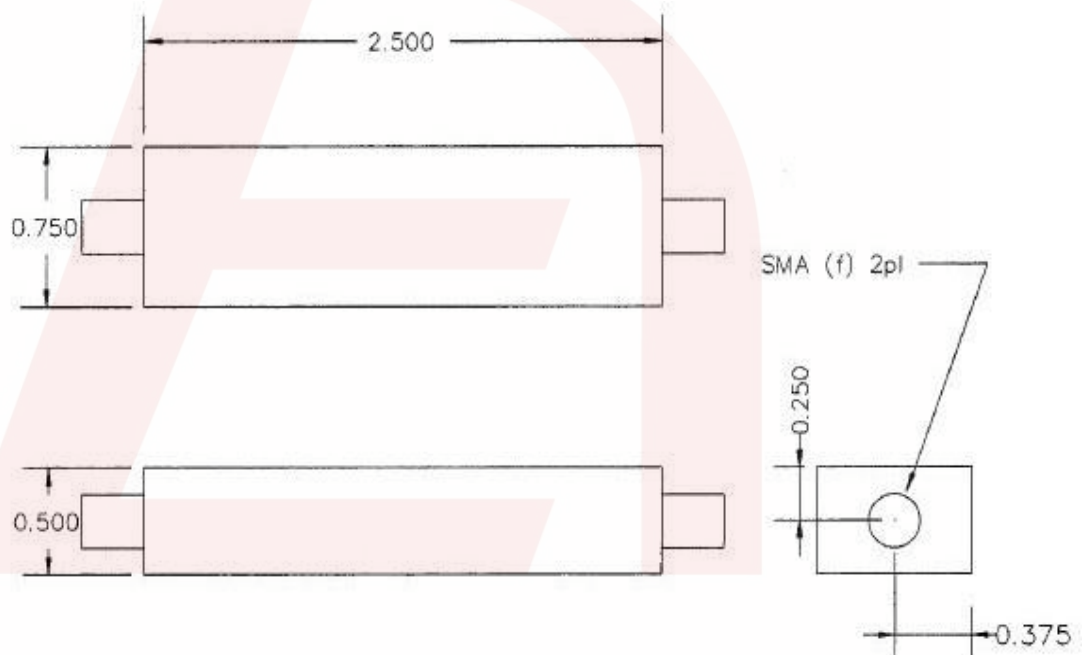

DS-H9835-04102019-Rev1



Response Plot :

3/15/2021 10:16:39 AM

