



**ANATECH ELECTRONICS INC**  
RF & Microwave Filters & Products

**1030 MHz Mono Block**

**Ceramic Bandpass Filter**

**Part Number: AE1030CB1863**



**Electrical specifications**

**Center Frequency:** 1030 MHz  
**Passband:** 1022.5 – 1037.5 MHz  
**1 dB Bandwidth:**  $F_o \pm 7.5$  MHz  
**Insertion Loss in BW:** 3.0 dB Max  
**Ripple in BW:** 1.0 dB Max  
**VSWR in BW:** 2.0:1 Max  
**Attenuation:** 40 dB Min @  $f_o \pm 60$  MHz  
60 dB Min @  $f_o \pm 120$  MHz  
**Input / Output Impedance:** 50 Ohms  
**Power Handling:** 2 W

**Mechanical**

**Mounting Method:** Surface Mount  
**Dimensions:** 27 x 12 x 6.5 mm

**Environmental**

**Operating Temperature:** -40 C to 85 C  
**Storage Temperature:** -55 C to +85 C  
**Shock:** 10 G. 11ms  
**Vibration:** 10 G. 5 to 200 Hz

**Outline Drawing:**

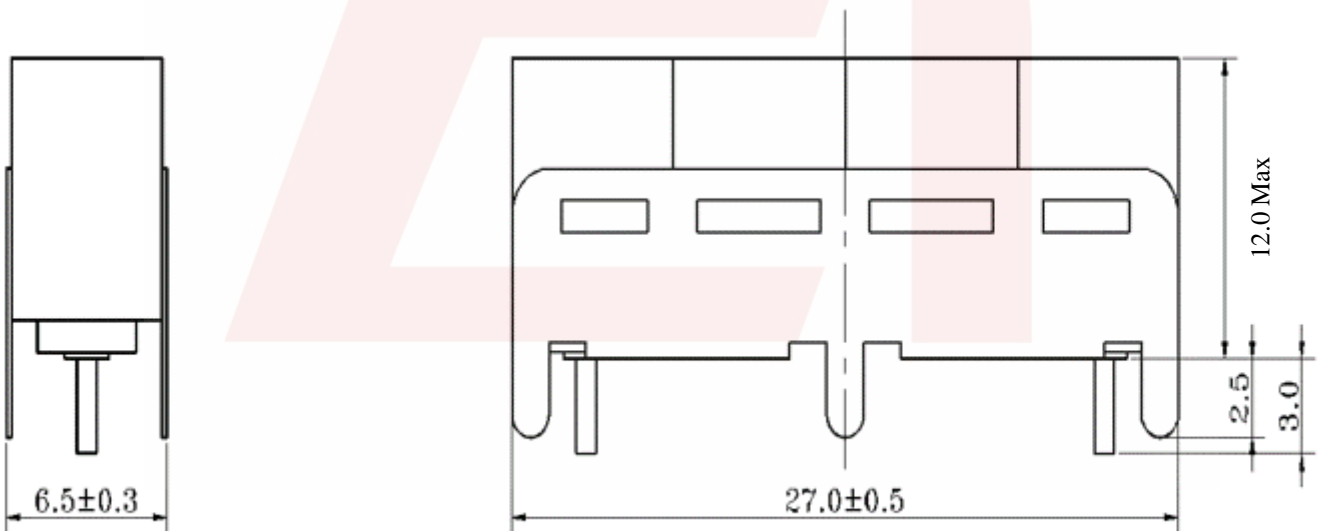

DS-CB1863-07202023-Rev0