



ANATECH ELECTRONICS INC
RF & Microwave Filters & Products

114 MHz LC Bandpass Filter

Part Number: AE114B9666



Electrical Specifications

Center Frequency: 114 MHz
Bandwidth: 5 MHz
Passband : 111.5 MHz to 116.5 MHz
Insertion Loss: $\leq 6\text{dB}$ @ 114 MHz
Return Loss: $>14\text{dB}$ @ 114 MHz
Rejection: $>50\text{dB}$ @ 0-101 MHz
Rejection2: $>50\text{dB}$ @ 130 MHz - 1000 MHz
Impedance: 50 Ohms

Mechanical

Mounting Method: Threaded Mounting Holes
Connector Type: BNC(F)
Dimensions: 2.380" x 1.0" x 1.0" in.

Environmental

Operating Temperature: -25°C to $+70^{\circ}\text{C}$
Storage Temperature: -40°C to $+90^{\circ}\text{C}$
Shock: 10 G. 11ms
Vibration: 10 G. 5 to 200Hz

Outline Drawing:

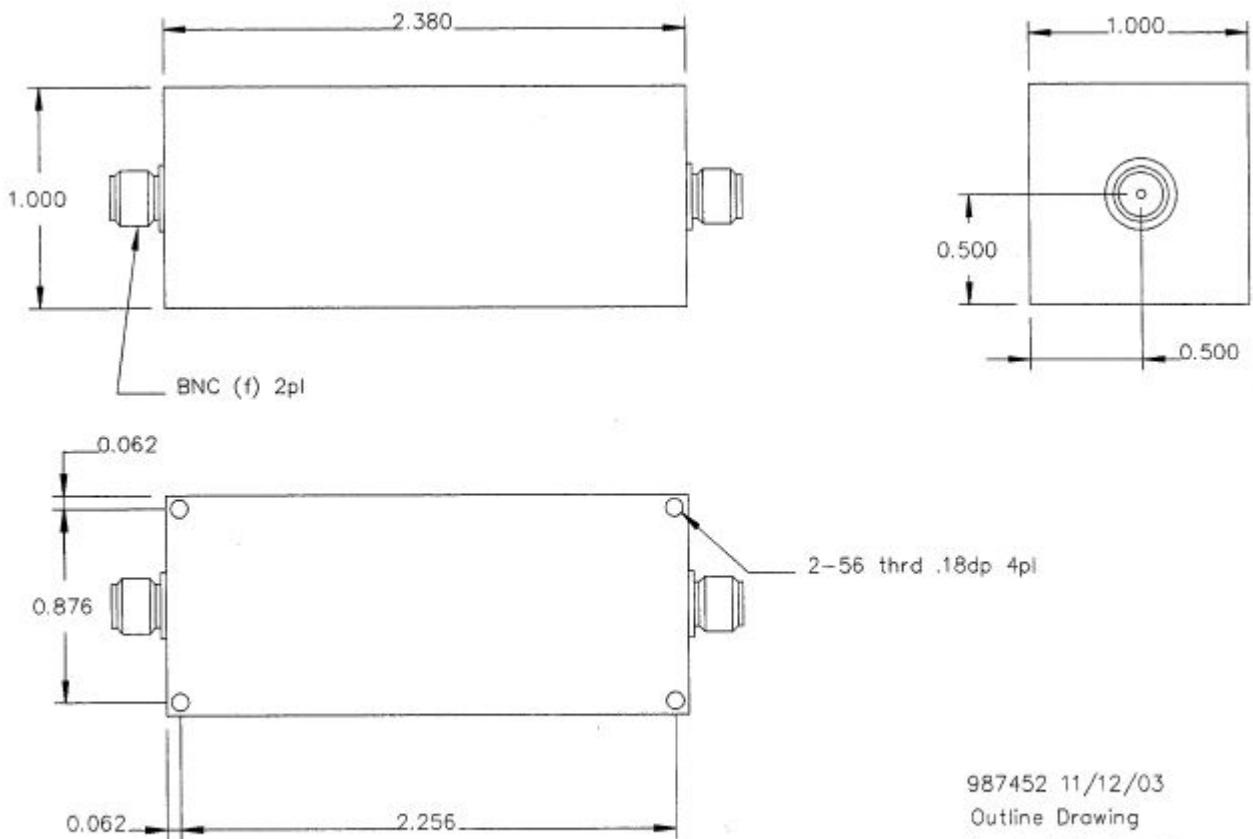

987452 11/12/03
Outline Drawing
Anatech Electronics
(987007)



Response Plot:

