



**ANATECH ELECTRONICS INC**  
RF & Microwave Filters & Products

# 14.7 MHz LC Band Pass Filter

**Part Number: AE14B11571**



## Electrical Specifications

**Center Frequency:** 14.7 MHz  
**Bandwidth:** 2.0 MHz  
**Pass Band:** 13.7-15.7 MHz  
**Insertion Loss:** 0.3 dB Max  
**Return Loss:** 14 dB Min (Goal 23 dB)  
**Rejection:** >40 dB @ 0-5 MHz  
                   >40 dB @ 30-500  
**Power:** 100 Watts  
**Impedance:** 50 Ohm

## Mechanical

**Connector Type:** N-Type (F)  
**Dimensions:** 5.10 x 2.0 x 1.5 Inches

## Environmental

**Operating Temperature:** -40 to +85° C  
**Storage Temperature:** -50 to +95° C

### Outline Drawing:

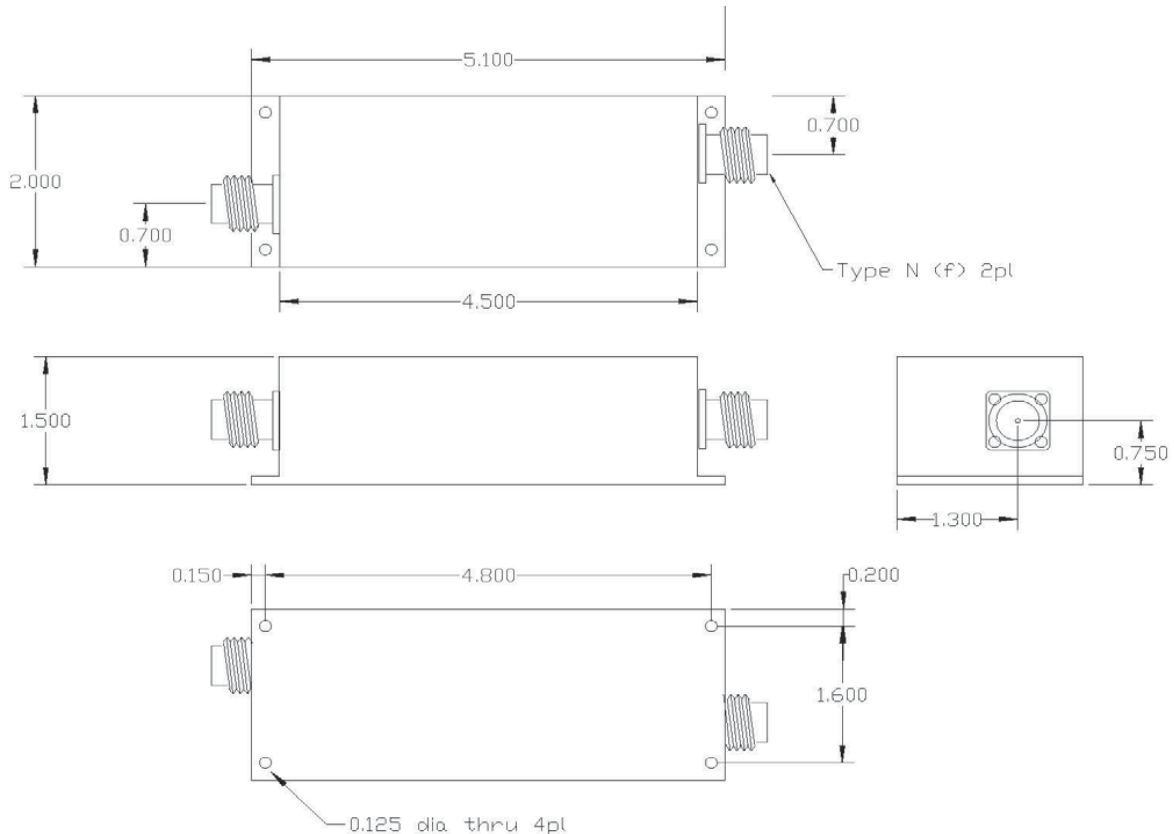

Tolerance: +/-0.01 inches [ +/- 0.3mm]  
 Angles: +/- 1 Deg.

\*Tolerance as shown unless otherwise specified in the datasheet electrical specification tables above.

\*When max dimensions are called out the above tolerances do not apply as long as it is under the max call out.



**Response Plot:**

