



**ANATECH ELECTRONICS INC**  
RF & Microwave Filters & Products

# 15.285 GHz Cavity Bandpass Filter

Part Number: AE15285B9649



## Electrical specifications

**Center Frequency:** 15.285 GHz  
**Bandwidth:** 0.12 GHz  
**Input / Output Impedance:** 50 Ohms  
**3dB Passband:** 15.225 – 15.345 GHz  
**Center Frequency Insertion Loss:** 4 dB Max  
**Passband Ripple:** 0.2 dB Max  
**Passband Return Loss:** 14 dB Min  
**Rejection 1:** 50 dB Min @ DC – 15.13 GHz  
**Rejection 2:** 50 dB Min @ 15.44 – 20 GHz  
**Impedance:** 50 Ohms In/Out  
**Power Handling:** 25 W

## Mechanical

**Mounting Method:** Panel Receptacle, 4 hole  
**Connector Type:** SMA (M-F)  
**Dimensions:** 2.5" x 0.5" x 0.5"

## Environmental

**Operating Temperature:** -45 to +85 deg.C  
**Storage Temperature:** -55 to +95 deg.C  
**Shock:** 20 G. 11ms  
**Vibration:** 20 G. 5 to 200 MHz

## Outline Drawing:

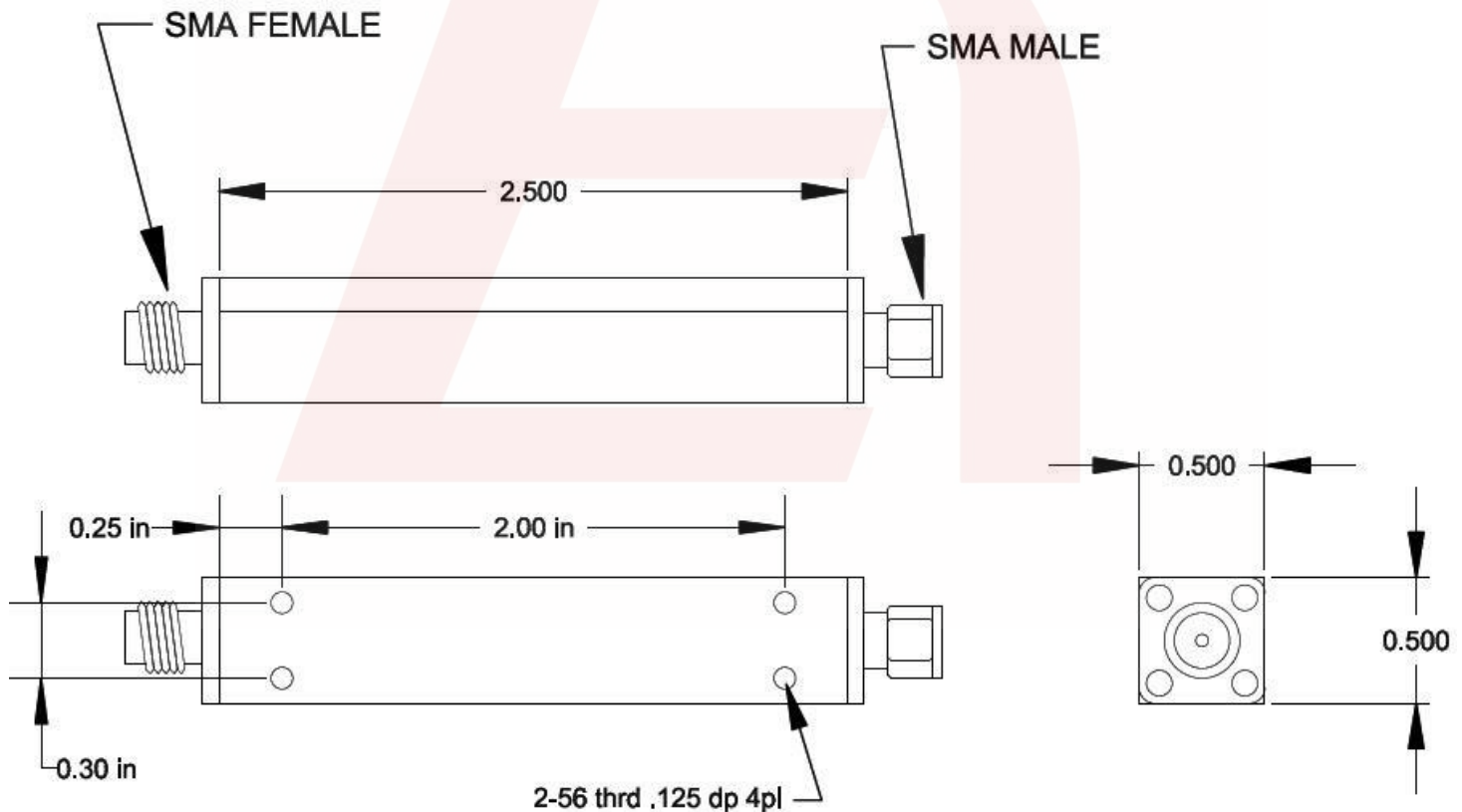

DS-B9649-09052023-Rev0