



**ANATECH ELECTRONICS INC**  
RF & Microwave Filters & Products

# 15350-15750 MHz Bandpass Filter

Part Number: AE15550B11320



## Electrical specifications

**Center Frequency (Fc):** 15550 MHz  
**Passband:** 15350 - 15750 MHz  
**Passband IL:** 1.0 dB Max @ Fc  
**Passband Ripple:** 0.5 dB Max  
**Return Loss:** 14 dB Min  
**Rejection:** 40 dB Min @ 13.80 GHz  
**Rejection:** 40 dB Min @ 18.60 GHz  
**Impedance:** 50 Ohms In/Out  
**Power Handling:** 150 W CW

## Mechanical

**Mounting Method:** 4-40 Threaded Hole  
**Connector Type:** N-Female/N-Male  
**Dimensions:** 3.15" x 1.25" x 1.00" in  
80 x 31.8 x 25.4 mm

## Environmental

**Operating Temperature:** 0°C to +60°C

## Outline Drawing:

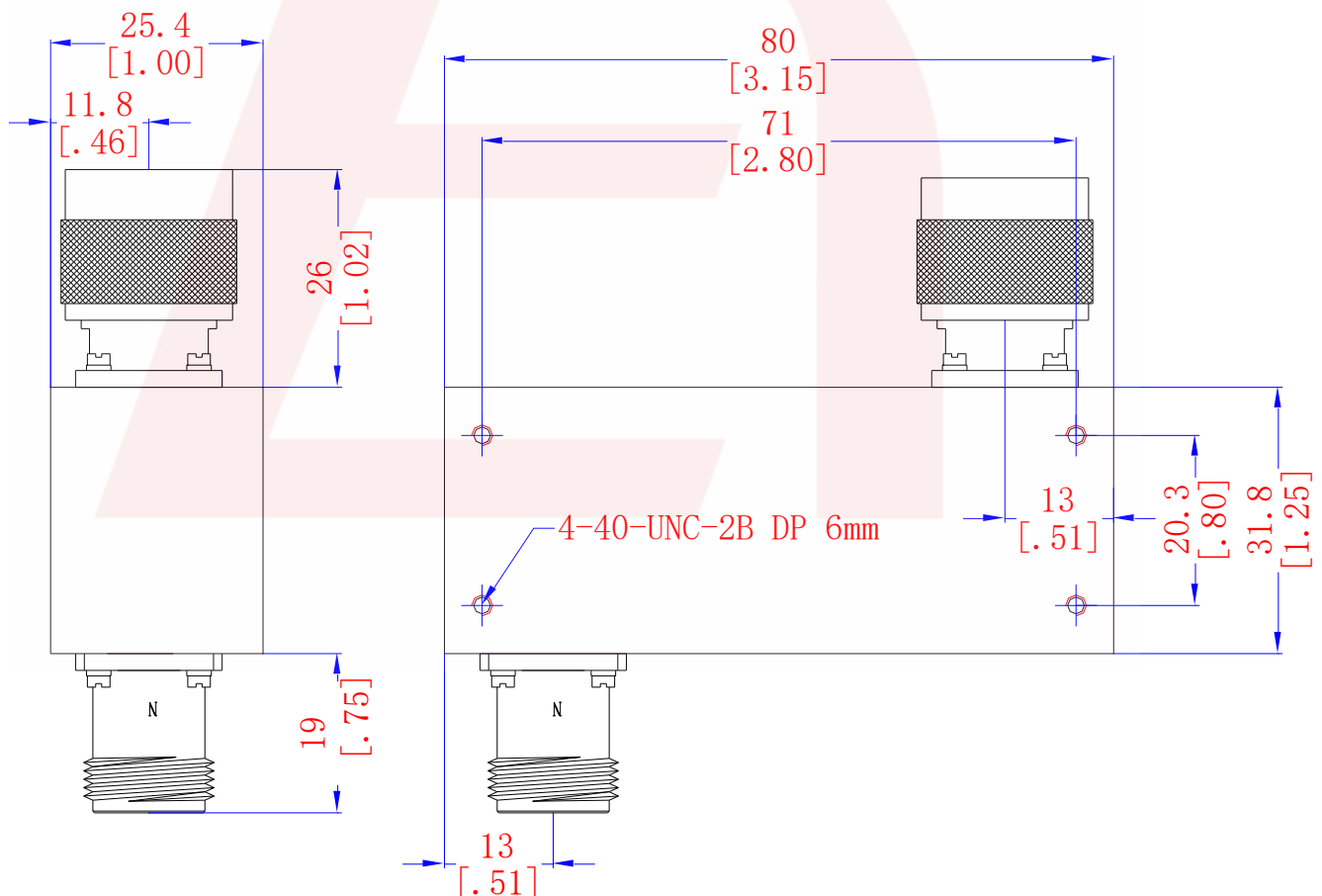

DS-B11320-06282024-Rev0