



ANATECH ELECTRONICS INC
RF & Microwave Filters & Products

30 MHz LC Bandpass Filter

Part Number: AE30LB12112



Electrical specifications

Center Frequency: 30 MHz

Bandwidth: 2 MHz Min

Passband (Pb): 29 – 31 MHz

Insertion Loss: 2.0 dB

Return Loss: 15 dB

Rejection on Low Side Pb: 50 dB Min @ 24 MHz

Rejection on High Side Pb: 50 dB Min @ 36 MHz

Input / Output Impedance: 50 Ohms

Mechanical

Connector Type: BNC (F)

Dimensions: 2.50 x 1.125 x 0.75 in.

Environmental

Operating Temperature: -45 to +85 deg.C

Storage temperature: -55 to +95 deg.C

Shock: 10 G 11ms

Vibration: 10 G 10-200 Hz

Outline Drawing:

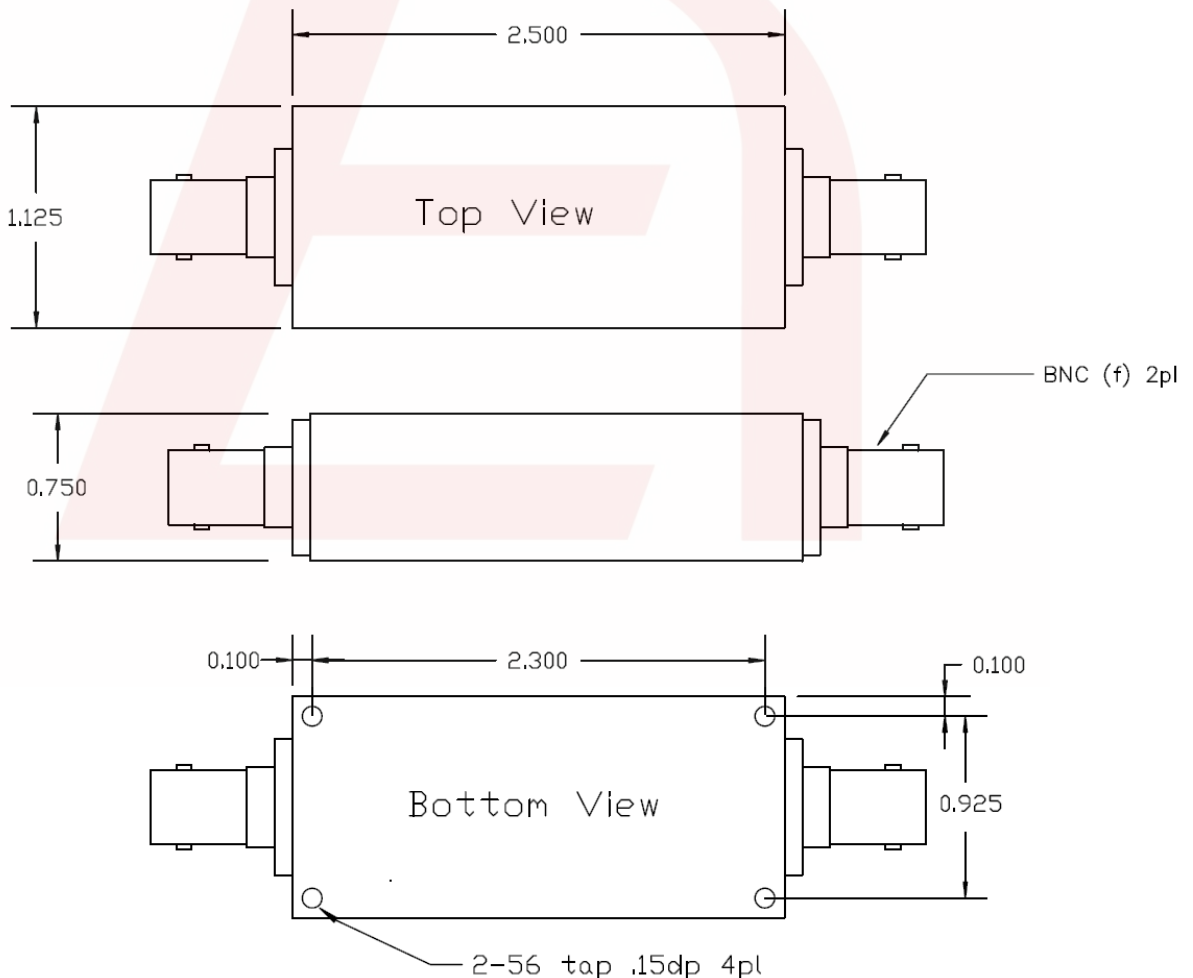

DS-B12112-03122024-Rev0