



### Electrical Specifications

**Center Frequency:** 3550 MHz  
**Passband:** 2200 - 4900 MHz  
**Insertion Loss in Passband:** 1.5 dB Max  
**Return Loss in Passband:** 15 dB Min  
**Rejection Frequency:** 30 dB Min @ DC - 1800 MHz  
**Rejection Frequency:** 30 dB Min @ 5300 - 6500 MHz  
**Impedance:** 50 ohms In/Out  
**Power Handling:** 20 W CW

### Mechanical

**Mounting Method:** N/A  
**Connector Type:** SMA (F)  
**Dimensions:** 3.149" x 1.299" x 0.472" in.

### Environmental

**Operating Temperature:** -45°C to +85°C  
**Storage Temperature:** -55°C to +95°C  
**Shock:** 10 G. 11ms  
**Vibration:** 10 G. 5 to 200 Hz

### Outline Drawing:

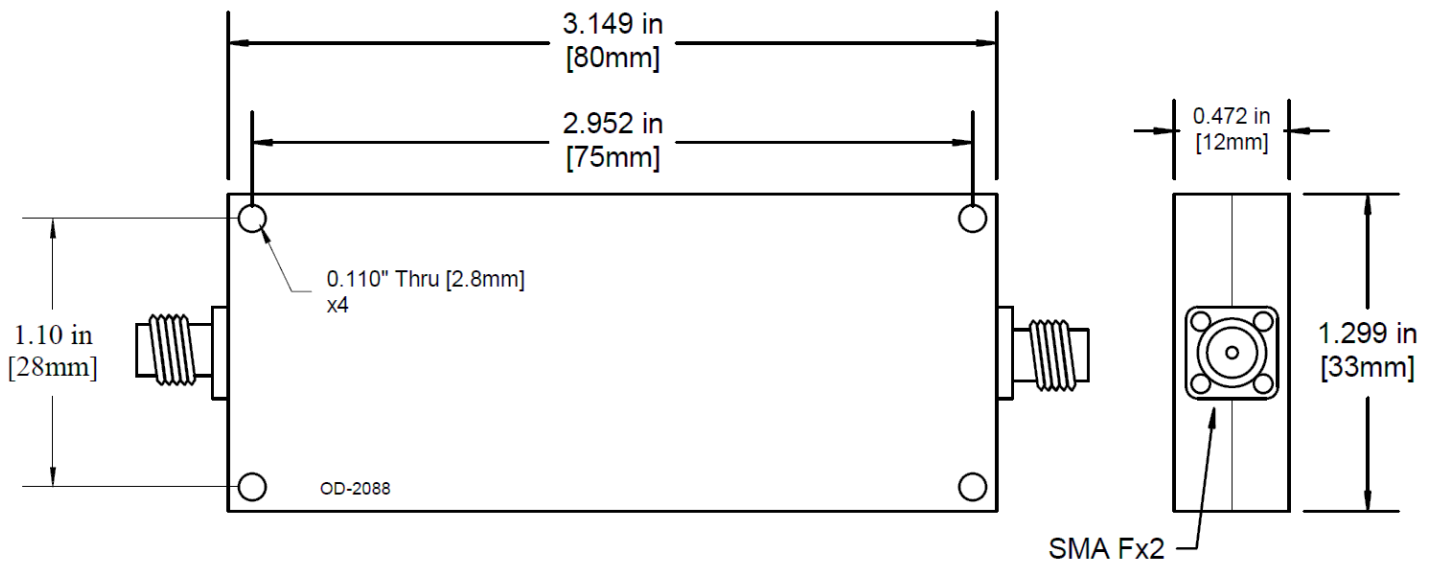



### Response Plot:

