



**ANATECH ELECTRONICS INC**  
RF & Microwave Filters & Products

# 275-500 MHz LC Bandpass Filter

Part Number: AE387B10680



## Electrical specifications

**Center Frequency:** 387 MHz  
**Bandwidth:** 225 MHz  
**Passband:** 275-500 MHz  
**Insertion Loss:** 3 dB Max  
**Return Loss:** 13 dB Min @ 297 – 477 MHz  
**Return Loss:** 10 dB @ 275 MHz  
**Return Loss:** 10 dB @ 500 MHz  
**Rejection:** >40 dB @ 245 MHz  
**Rejection:** >40 dB @ 550 MHz  
**Power Handling:** 10 W CW

## Mechanical

**Connector Type:** SMA (F)  
**Dimensions:** 4.0 x 0.6 x 0.5 in

## Environmental

**Operating Temperature:** -55°C to +85°C  
**Shock:** 30 G. 11ms  
**Vibration:** 10 G. 5 to 1000 Hz

## Outline Drawing:

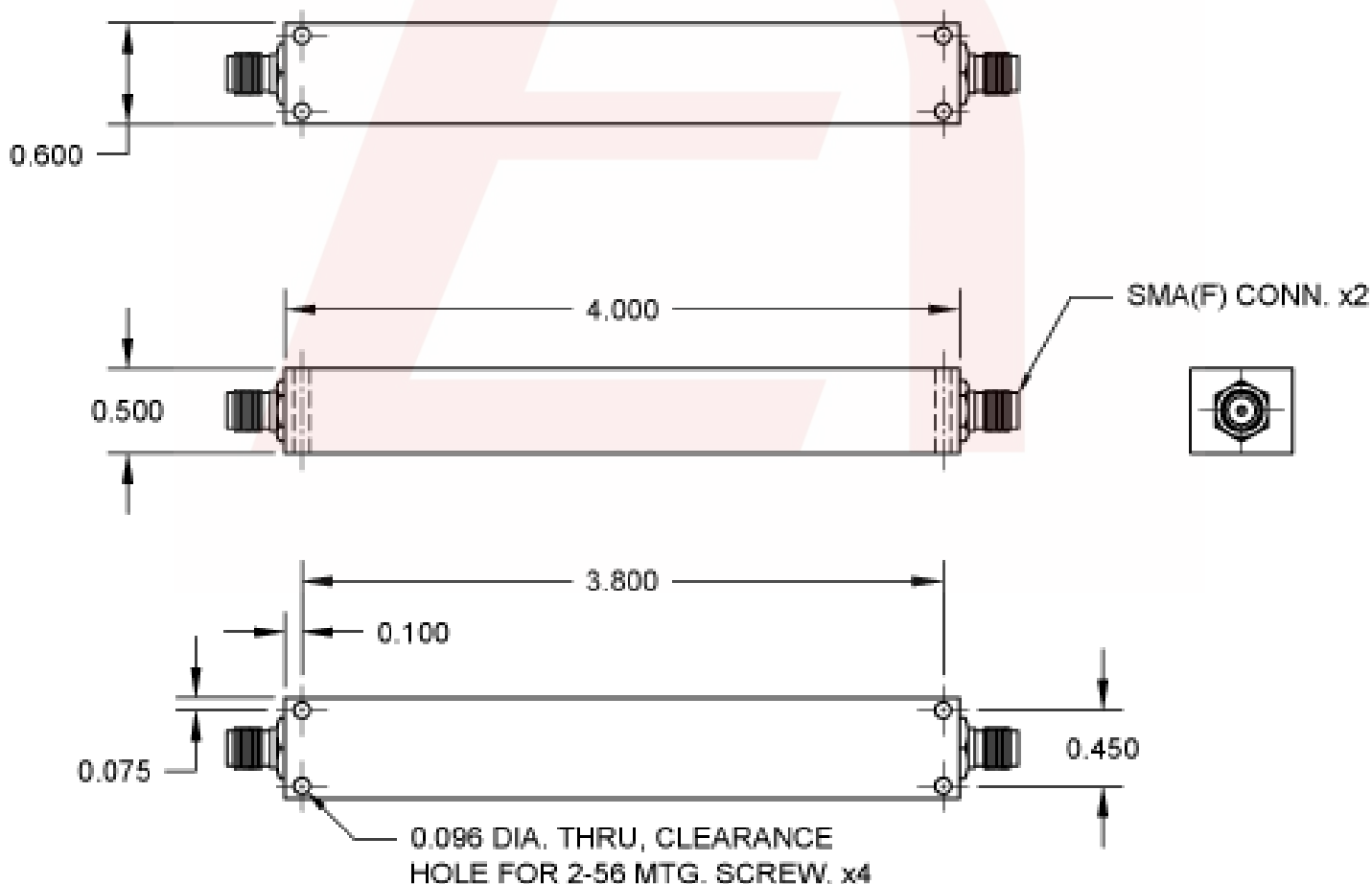

DS-B10680-01102025-Rev3



# 275-500 MHz LC Bandpass Filter

**Part Number: AE387B10680**



## Response Plot:

A144.lad

001 5, 2010

Attenuation/Return Loss

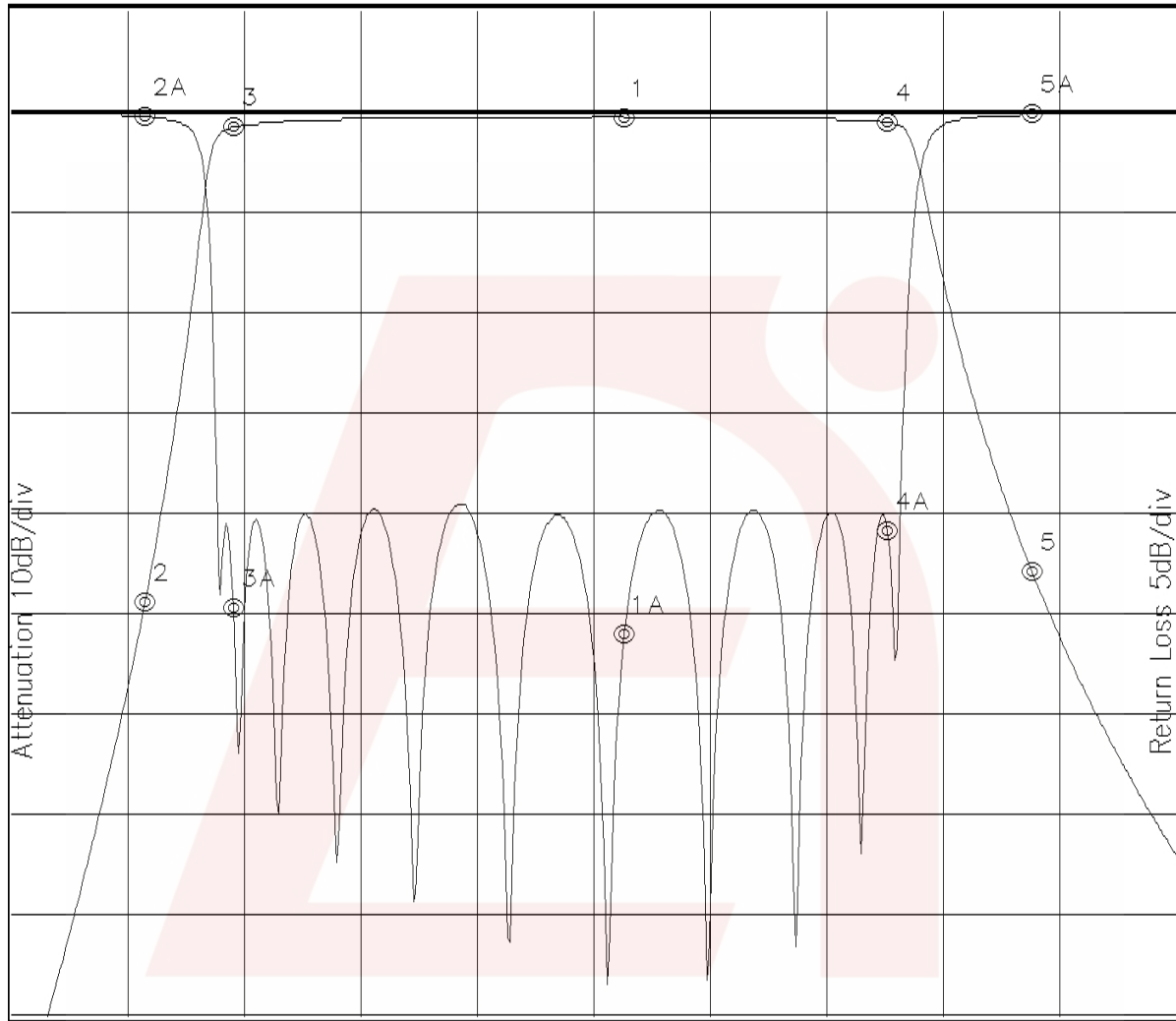

Attenuation Start: 200.0MHz Stop: 600.0MHz Return Loss Start: 200.0MHz Stop: 600.0MHz

Marker 1 Freq 410.01MHz Atten -0.544dB  
 Marker 2 Freq 245.23MHz Atten -49.182dB  
 Marker 3 Freq 275.60MHz Atten -1.560dB  
 Marker 4 Freq 500.48MHz Atten -1.079dB  
 Marker 5 Freq 550.24MHz Atten -46.137dB

Marker 1A Freq 410.01MHz Ret Loss -26.197dB  
 Marker 2A Freq 245.23MHz Ret Loss -0.237dB  
 Marker 3A Freq 275.60MHz Ret Loss -24.844dB  
 Marker 4A Freq 500.48MHz Ret Loss -20.959dB  
 Marker 5A Freq 550.24MHz Ret Loss -0.146dB