



Electrical Specifications

Center Frequency: 510 MHz
0.5 dB Bandwidth: 4 MHz
3 dB Bandwidth: 8 MHz
Passband: 506-514 MHz
Insertion Loss @ Fo: 7.0 dB (Goal 5 dB) Max
Ripple: ±0.20 dB @ 506-514 MHz
VSWR: 1.5:1 Max
Phase Linearity: 3.0° Max @ 506-514 MHz
Rejection: >10 dB @ 495 & 530 MHz
 >20 dB @ 490 & 540 MHz
 >30 dB @ 480 & 550 MHz
 >40 dB @ 470 & 575 MHz
 >60 dB @ 450 & 600 MHz

Average Power: 1 Watt

Mechanical

Mounting Method: PC Mount
Dimensions: 1.24 x 0.43 x 0.3 Inches

Environmental

Operating Temperature: -20 to +60° C
Operating Temperature: -45 to +85 C

Outline Drawing:

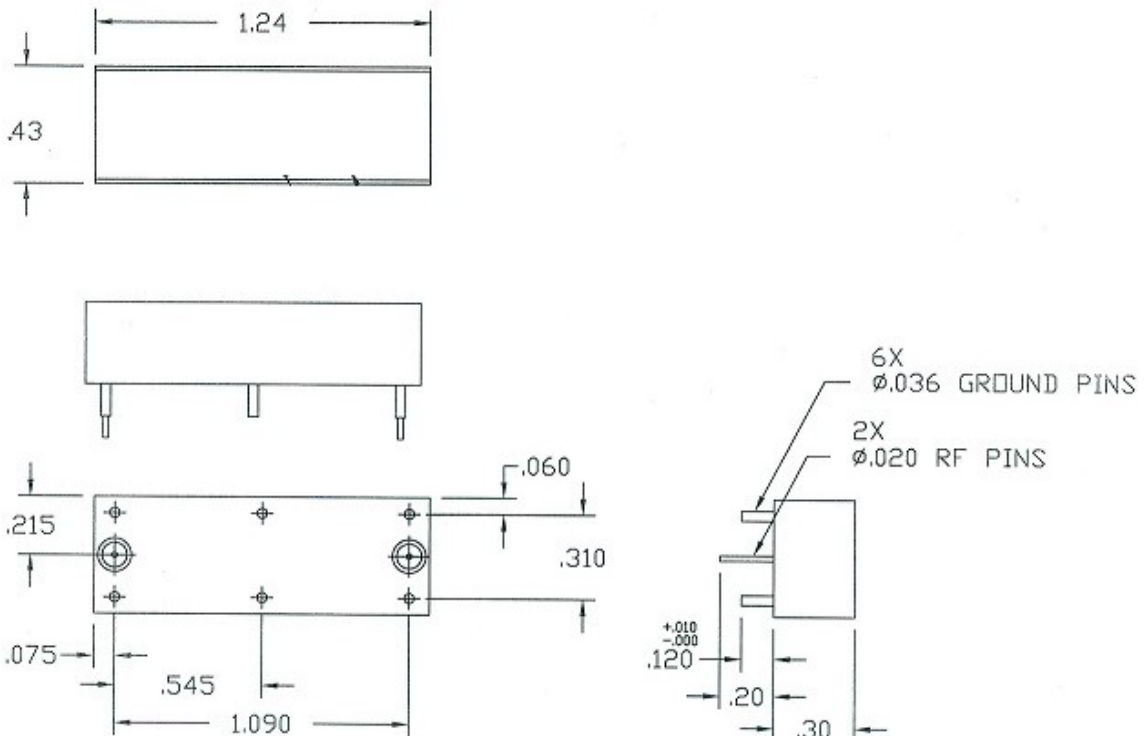



510 MHz Bandpass Filter

Part Number: AE510B11813



Response Plot:

A451.lad

DEC 5, 2014

Attenuation/Return Loss

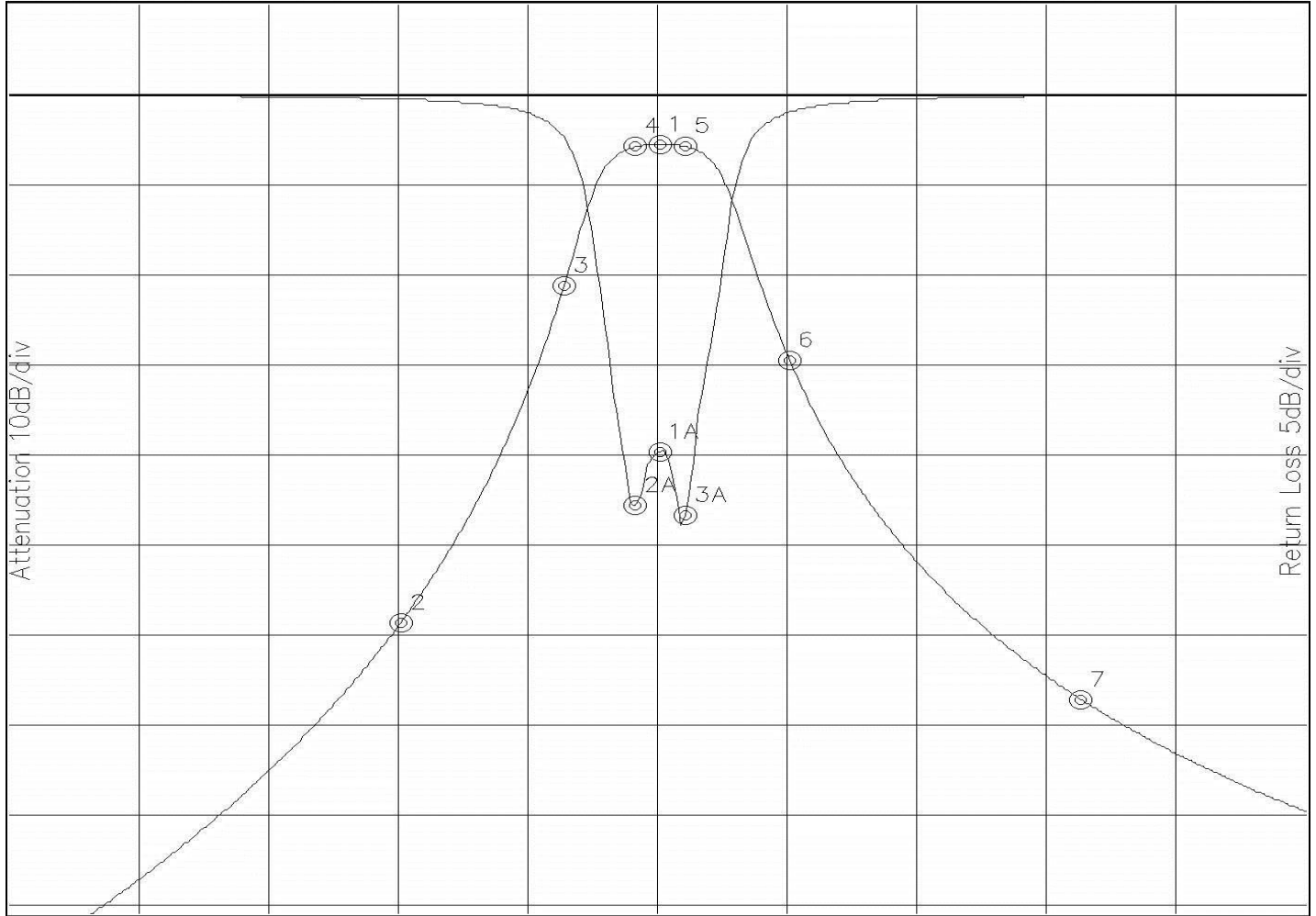

Attenuation Start: 410.0MHz Stop: 610.0MHz

Return Loss Start: 410.0MHz Stop: 610.0MHz

Marker 1 Freq 510.16MHz Atten -5.393dB
 Marker 2 Freq 470.09MHz Atten -58.447dB
 Marker 3 Freq 495.29MHz Atten -21.097dB
 Marker 4 Freq 506.28MHz Atten -5.741dB
 Marker 5 Freq 514.03MHz Atten -5.652dB
 Marker 6 Freq 530.19MHz Atten -29.338dB
 Marker 7 Freq 575.10MHz Atten -66.885dB

Marker 1A Freq 510.16MHz Ret Loss -19.730dB
 Marker 2A Freq 506.28MHz Ret Loss -22.751dB
 Marker 3A Freq 514.03MHz Ret Loss -23.219dB



Phase Linearity:

A451.lad

DEC 5, 2014

Phase

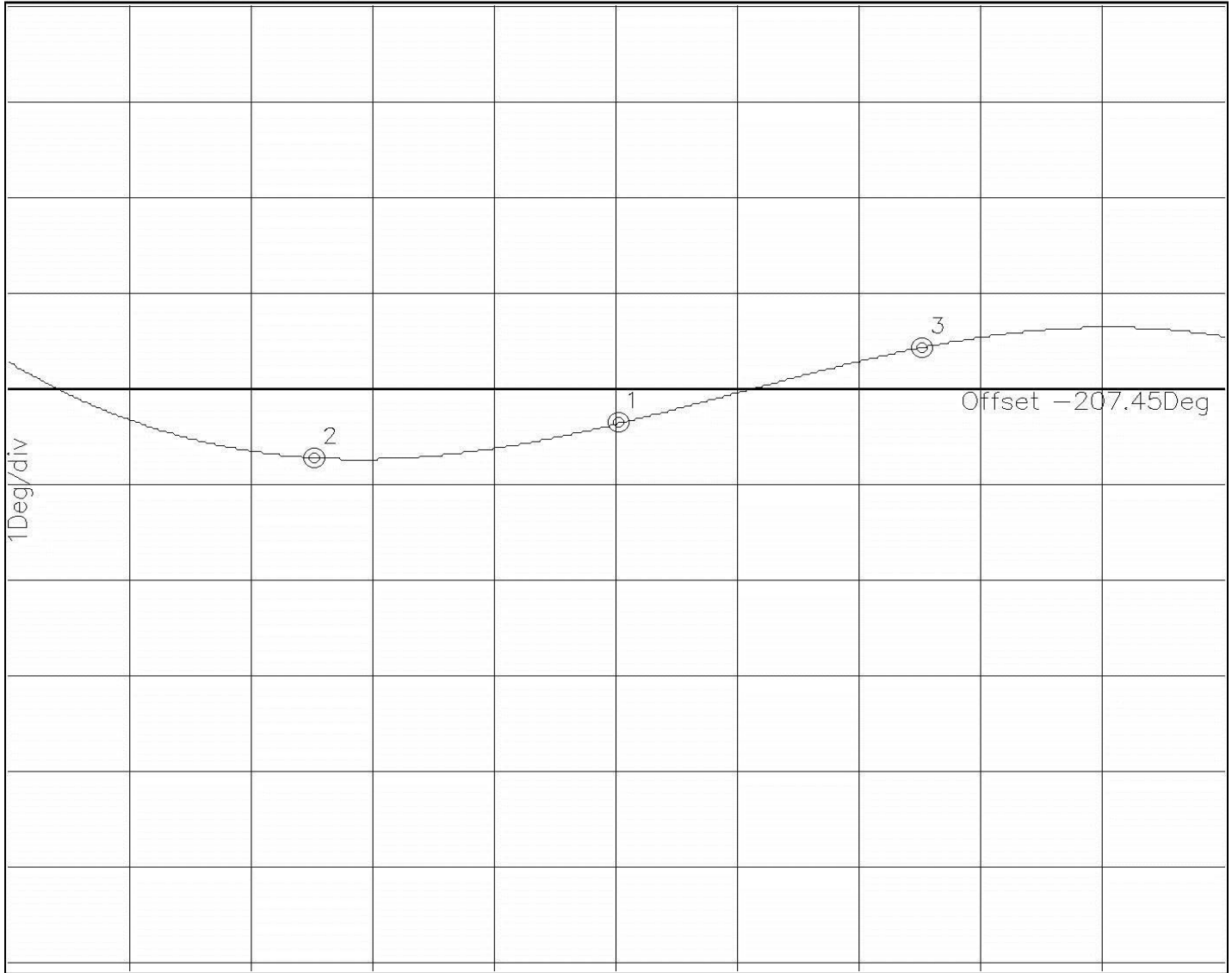

Phase Start: 506.0MHz Stop: 514.0MHz

Marker 1 Freq 510.00MHz Phase -0.357Deg

Marker 2 Freq 508.00MHz Phase -0.716Deg

Marker 3 Freq 512.01MHz Phase 0.436Deg