



Electrical Specifications

Center Frequency: 5150 MHz
Bandwidth: 300 MHz
Passband: 5000 – 5300 MHz
Insertion Loss: 0.5 dB Max
Return Loss: 12 dB Min
Rejection: 60 dB Min @ 4800 MHz
 60 dB Min @ 5500 – 11000 MHz
Impedance: 50 Ohms In/Out
Power Handling: 20 W CW Max

Mechanical

Connector Type: SMA Female
Dimensions: 3.47 x 1.70 x 1.06 in.
 88 x 43.2 x 27 mm

Environmental

Operating Temperature: -45°C to +80°C
Storage Temperature: -55°C to +90°C
Shock: 20 G. 11ms
Vibration: 20 G. 5 to 200Hz

Outline Drawing:

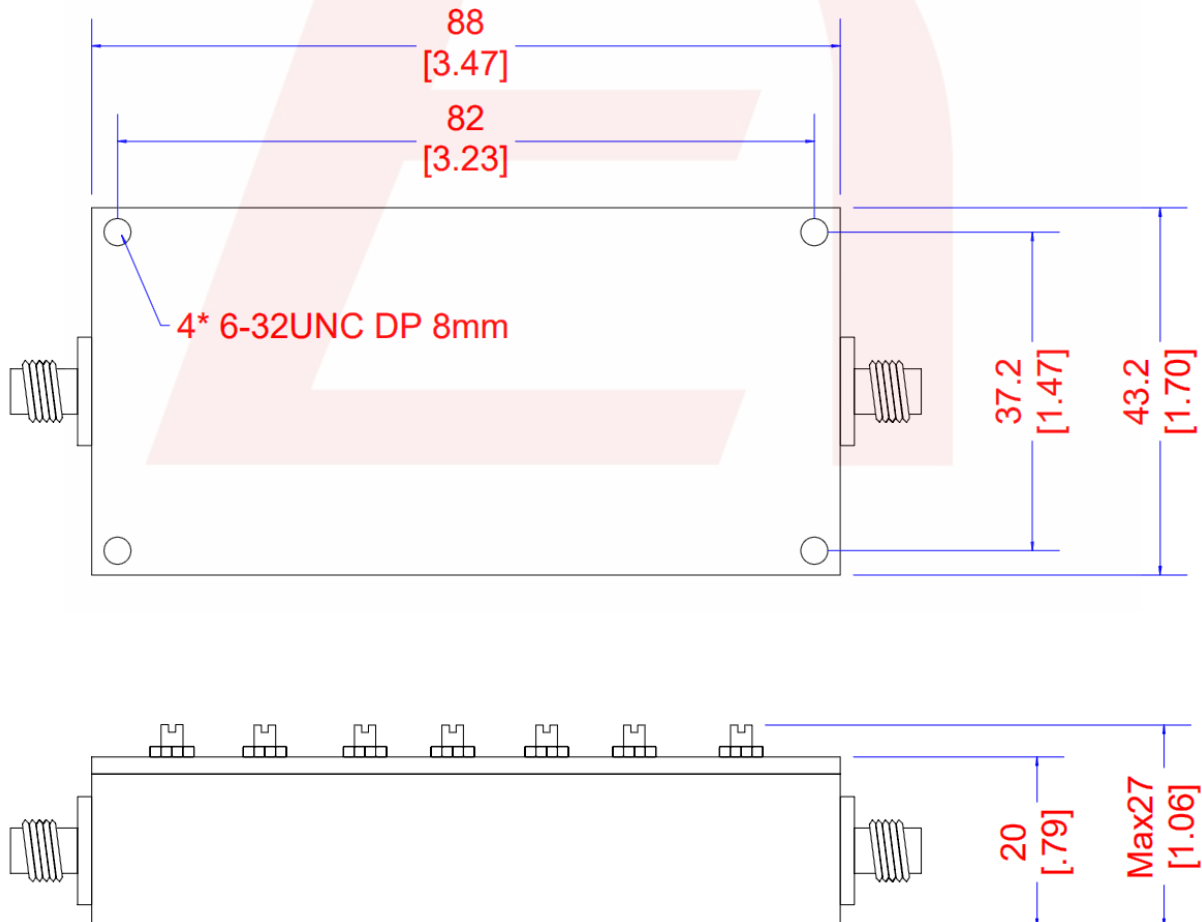

DS-B12145-SF-04292024-Rev0



Simulation Plot:

